

KOMATSU

PC16R-3



Mini-excavator

Engine power
11.6 kW / 15.6 HP @ 2600 rpm

Operating weight
1570 - 1920 kg

Bucket capacity
0.03 - 0.06 m³

PC16R-3



Engine power
11.6 kW / 15.6 HP @ 2600 rpm

Operating weight
1570 - 1920 kg

Bucket capacity
0.03 - 0.06 m³

High versatility, low fuel consumption and **safe performance in tight spaces**

Complete versatility

- Standard 1- or 2-way auxiliary line for attachments
- Numerous configurations available
- Ideal for a wide range of applications

Outstanding performance

- Low consumption EU Stage V engine
- Optimal power and digging speed in confined spaces
- Perfect control even during combined operations
- Fast and precise movements

Highest operator comfort

- Spacious working environment ensures outstanding comfort
- Excellent accessibility to and from the machine
- Pressure Proportional Control (PPC) servo-controls

Easy serviceability

- Easy access to all daily inspection points
- Tilting canopy / cab provides access for larger maintenance jobs
- Extended 500-hour service interval

Extremely robust

- Excellent stability and safety for maximum operator confidence in any conditions
- High quality standards guarantee longer lifetime for all components
- ROPS and OPG compliant canopy / cab

Komtrax (option)

- Komatsu Wireless Monitoring System
- 4G mobile communications
- Increased operational data for better fleet management



Outstanding performance

Outstanding performance

The easy-to-use PC16R-3 allows all operators to get the best from their machine – whether they are experts or novices. The controls are user-friendly and dedicated to each movement. Smooth operations, enhanced by the CLSS hydraulic system, in combination with perfect visibility of the working area guarantee maximum productivity in even the toughest situations.



Highest operator comfort



Highest operator comfort

Designed with the utmost attention to detail, the operator's environment ensures outstanding comfort, accessibility and visibility. The canopy or cab allows easy access to and from the machine. Once seated, the spacious, obstacle-free floor allows even the tallest operators room to move their legs.

For even greater comfort, an adjustable seat and PPC controls are fitted as standard.



The two-speed tracking is operated via a switch on the dashboard. The dashboard also allows the operator to monitor all machine functions.

Extremely robust



Extremely robust

A number of particular technical solutions contribute to the PC16R-3's increased sturdiness and operability. These include a cast swing support that makes the structure extremely rigid, and a boom that houses the hydraulic hoses, protecting them from possible damage and guaranteeing the best visibility of the digging area. Furthermore, the choice of metal for the bonnets and covers guarantees a longer life and lower repair costs in case of collision.



Complete versatility



Customisation

With many configurations available, you can choose exactly the right machine for a specific job: long or short arm, canopy or cab, rubber or steel shoes, standard or extendible undercarriage. Moreover, the 1- / 2-way auxiliary hydraulic circuit allows the use of a wide range of working tools like a hammer, clamshell bucket, auger etc.

Variable undercarriage

For applications requiring maximum versatility in terms of size and stability, the PC16R-3 is also available with hydraulic undercarriage extension, which is operated from the operator's seat via a push button and the blade control lever. This feature allows the operator to quickly switch from maximum stability for working to a reduced width of less than one metre for driving through narrow passages or doors.



Easy serviceability



Easy serviceability

All periodic inspection points are easily accessible through the machine's bonnets. In addition, larger maintenance tasks can be performed by simply tilting the canopy / cab upwards.

ORFS hydraulic face seal connectors and DT electrical connectors enhance the machine's reliability and makes repairs faster and easier. Special technical solutions have allowed the interval for most ordinary maintenance operations, such as pin greasing and engine oil changes, to be extended to up to 500 hours.



Right bonnet: simple inspection and cleaning of the radiators



Rear bonnet: quick engine check and fuel tank refilling



Left bonnet: easy access to the battery refilling

Information & communication technology



Knowledge

You get quick answers to basic and critical questions about your machines – what they're doing, when they did it, where they're located, how they can be used more efficiently and when they need to be serviced. Performance data is relayed by wireless communication technology (satellite, GPRS or 4G depending on model) from the machine to a computer and to the local Komatsu distributor – who's readily available for expert analysis and feedback.

Convenience

Komtrax enables convenient fleet management on the web, wherever you are. Data is analysed and packaged specifically for effortless and intuitive viewing in maps, lists, graphs and charts. You can foresee eventual maintenance issues and required spare parts, and troubleshoot a problem before Komatsu technicians arrive on site.



The way to higher productivity

Komtrax uses the latest wireless monitoring technology. Compatible on PC, smartphone or tablet, it delivers insightful and cost saving information about your fleet and equipment, and offers a wealth of information to facilitate peak machine performance. By creating a tightly integrated web of support it allows proactive and preventive maintenance and helps to efficiently run a business.

Power

The detailed information that Komtrax puts at your fingertips 24 hours a day, 7 days a week gives the power to make better daily and long-term strategic decisions – at no extra cost. Problems can be anticipated, maintenance schedules customised, downtime minimised and machines kept where they belong: working on the jobsite.



Specifications

Engine

Model	Komatsu 3D67E-2A
Type	Emissionised 4-cycle diesel engine
Engine power	
at rated engine speed	2600 rpm
ISO 14396	11.6 kW / 15.6 HP
ISO 9249 (net engine power)	11.2 kW / 15.0 HP
Displacement	778 cm ³
No. of cylinders	3
Max. torque / engine speed	44.1 Nm / 1800 rpm
Cooling system	Water
Air filter type	Dry
Starter motor	Electric motor with pre-heating air system for cold climate

Operating weight (appr.)

Operating weight with rubber shoes	1570 kg
Operating weight with steel shoes	1630 kg
Heated cab weight	+120 kg (optional)
Variable undercarriage	+170 kg

Operating weight with standard bucket, fully serviced, +75 kg operator (ISO 6016).

Hydraulic system

Type	Komatsu CLSS
Main pumps	1 × variable displacement pump
Max. pump flow	40.8 l/min
Max. operating pressure	21 MPa (210 bar)
Bucket digging force	1150 kg
Arm crowd force (ISO 6015)	
965 mm arm	900 daN (920 kg)
1215 mm arm	715 daN (730 kg)

The digging equipment is fully controlled by PPC servo-controls. All movements are stopped by lifting the safety lever on the tilting case.

Transmission

Type	Double speed hydrostatic transmission, controlled and steered by means of two levers or two pedals
Hydraulic motors	2 × axial piston motor
Reduction system	Planetary gear
Maximum drawbar pull	1490 daN (1520 kgf)
Max. travel speeds (Lo / Hi)	2.2 - 4.2 km/h

Swing system

The rotation is operated by means of an orbital hydraulic motor. Single ball-bearing ring with internal, induction hardened toothring. Centralised lubrication of the unit.

Swing speed	8.9 rpm
-------------	---------

Blade

Type	Electro-welded, single unit structure
Width × height	1020 × 250 mm
Max. lifting above ground level	280 mm
Max. depth below ground level	155 mm

Undercarriage

Track rollers (each side)	3
Shoe width	230 mm
Ground pressure (standard)	0.3 kg/cm ²

Service refill capacities

Fuel tank	19 l
Cooling system	3.1 l
Engine oil (redill)	3.3 l
Hydraulic system (refill)	1.2 l

Environment

Engine emissions	Fully complies with EU Stage V exhaust emission regulations
Vibration levels (EN 12096:1997)	
Hand/arm	≤ 2.5 m/s ² (uncertainty K = 1.2 m/s ²)
Body	≤ 0.5 m/s ² (uncertainty K = 0.2 m/s ²)

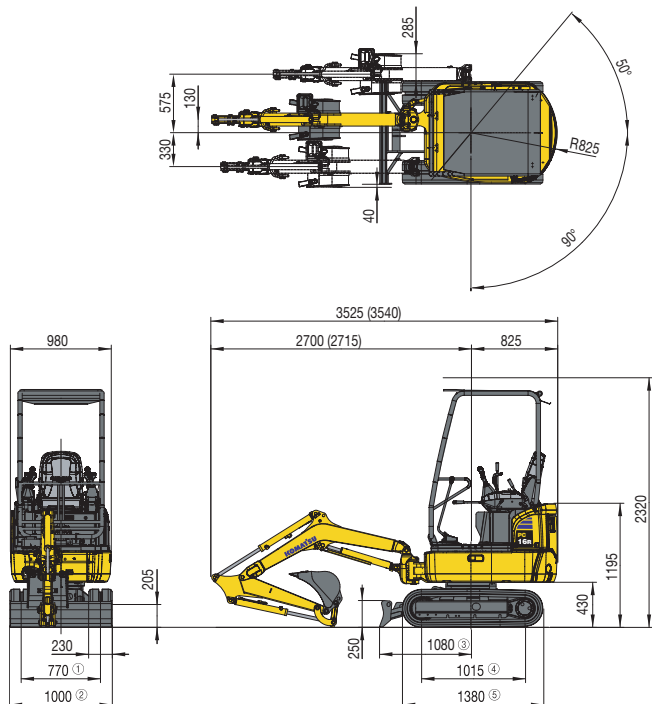

HS version:

1 750 - 1.070 mm	3 1.145 mm
2 980 - 1.300 mm	4 1.212 mm
	5 1.555 mm

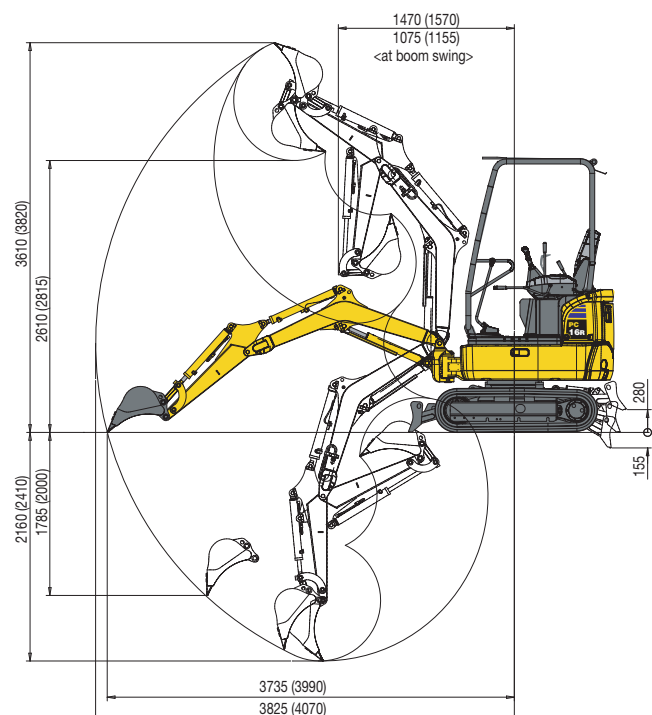

Bucket range

Width mm	Capacity m ³ (ISO 7451)	Weight kg	No. of teeth
250	0,03	19	2
300	0,035	20	3
350	0,04	22	3
400	0,05	23	3
450	0,06	25	4

Canopy, rubber shoes, 350 mm bucket, blade down

A - Distance from machine's center B - Height at bucket pin

Arm length 965 mm

B \ A	2 m		2,5 m		3 m		Max. outreach	
	Front	360°	Front	360°	Front	360°	Front	360°
2 m	(*)286	(*)286	(*)278	230	-	-	(*)279	172
1 m	(*)486	299	(*)364	217	(*)303	163	(*)284	142
0 m	(*)600	278	(*)426	204	(*)324	157	(*)296	146
-1 m	(*)480	281	(*)331	206	-	-	(*)298	196

Unit: kg

Arm length 1215 mm

B \ A	2 m		2,5 m		3 m		Max. outreach	
	Front	360°	Front	360°	Front	360°	Front	360°
2 m	-	-	(*)229	(*)229	(*)235	168	(*)242	145
1 m	(*)417	302	(*)324	216	(*)276	161	(*)247	122
0 m	(*)584	273	(*)412	200	(*)317	152	(*)259	125
-1 m	(*)525	271	(*)373	197	-	-	(*)266	159

Unit: kg

Canopy, rubber shoes, 350 mm bucket, blade down, HS version

A - Distance from machine's center B - Height at bucket pin

Arm length 965 mm

B \ A	2 m		2,5 m		3 m		Max. outreach	
	Front	360°	Front	360°	Front	360°	Front	360°
2 m	(*)286	(*)286	(*)278	(*)278	-	-	(*)279	(*)279
1 m	(*)486	(*)486	(*)364	353	(*)303	269	(*)284	237
0 m	(*)600	468	(*)426	340	(*)324	263	(*)296	244
-1 m	(*)480	471	(*)331	(*)331	-	-	(*)298	(*)298

Unit: kg

Arm length 1215 mm

B \ A	2 m		2,5 m		3 m		Max. outreach	
	Front	360°	Front	360°	Front	360°	Front	360°
2 m	-	-	(*)229	(*)229	(*)235	(*)235	(*)242	(*)242
1 m	(*)417	(*)417	(*)324	(*)324	(*)276	267	(*)247	209
0 m	(*)584	463	(*)412	336	(*)317	258	(*)259	214
-1 m	(*)525	461	(*)373	333	-	-	(*)266	(*)266

Unit: kg

NOTE:

Ratings are based on ISO standard 10567. Rated loads do not exceed 87% of hydraulic lift capacity or 75% of tipping load.

- The values marked with an asterisk (*) are limited by the hydraulic capacities.
- Calculations are based on the machine resting on a uniform and firm surface.
- The lifting point is a hypothetical hook placed behind the bucket.

Standard and optional equipment

Engine

Komatsu 3D67E-2A diesel engine	●
EU Stage V compliant	●
Two speeds with "Automatic Shift Down"	●
Alternator 12 V / 40 A	●
Starter motor 12 V / 1.2 kW	●
Batteries 12 V / 41 Ah	●

Hydraulic system

Komatsu closed-centre load sensing (CLSS) hydraulic system	●
1 / 2 way auxiliary hydraulic circuit for attachments up to the boom	●
Safety valve on bucket element	●
Extension of the auxiliary hydraulic circuit up to the arm, with quick couplings	○
Travel pedals	○

Undercarriage

Rubber shoes	●
Steel shoes	○
Variable undercarriage (HS version)	○

Lighting system

Working light on boom	●
Rotating beacon	○

Service and maintenance

Komtrax – Komatsu wireless monitoring system (4G)	○
---	---

Canopy / Cabin

ROPS (ISO 3471) - OPG (ISO 10262) level 1 canopy	●
Adjustable seat	●
ROPS (ISO 3471) - OPG (ISO 10262) level 1 tilting cab with heating	○

Safety equipment

Lifting cylinder guard	●
Audible travel alarm	●
Rear-view mirrors	○

Work equipment

965 mm digging arm	●
1215 mm digging arm	●
Bucket range (250 - 450 mm)	○
1000 mm ditch cleaning bucket	○

Other equipment

Biodegradable oil for hydraulic system	○
--	---

Further equipment on request

- standard equipment
- optional equipment

This specification sheet may contain attachments and optional equipment that are not available in your area. Please consult your local Komatsu distributor for those items you may require.

Materials and specifications are subject to change without notice.

Your Komatsu partner:

KOMATSU

komatsu.eu

